

Turmdrehkran 120 K.1

Tower Crane / Grue à tour / Gru a torre / Grúa torre
Guindaste de torre / Башенный поворотный кран

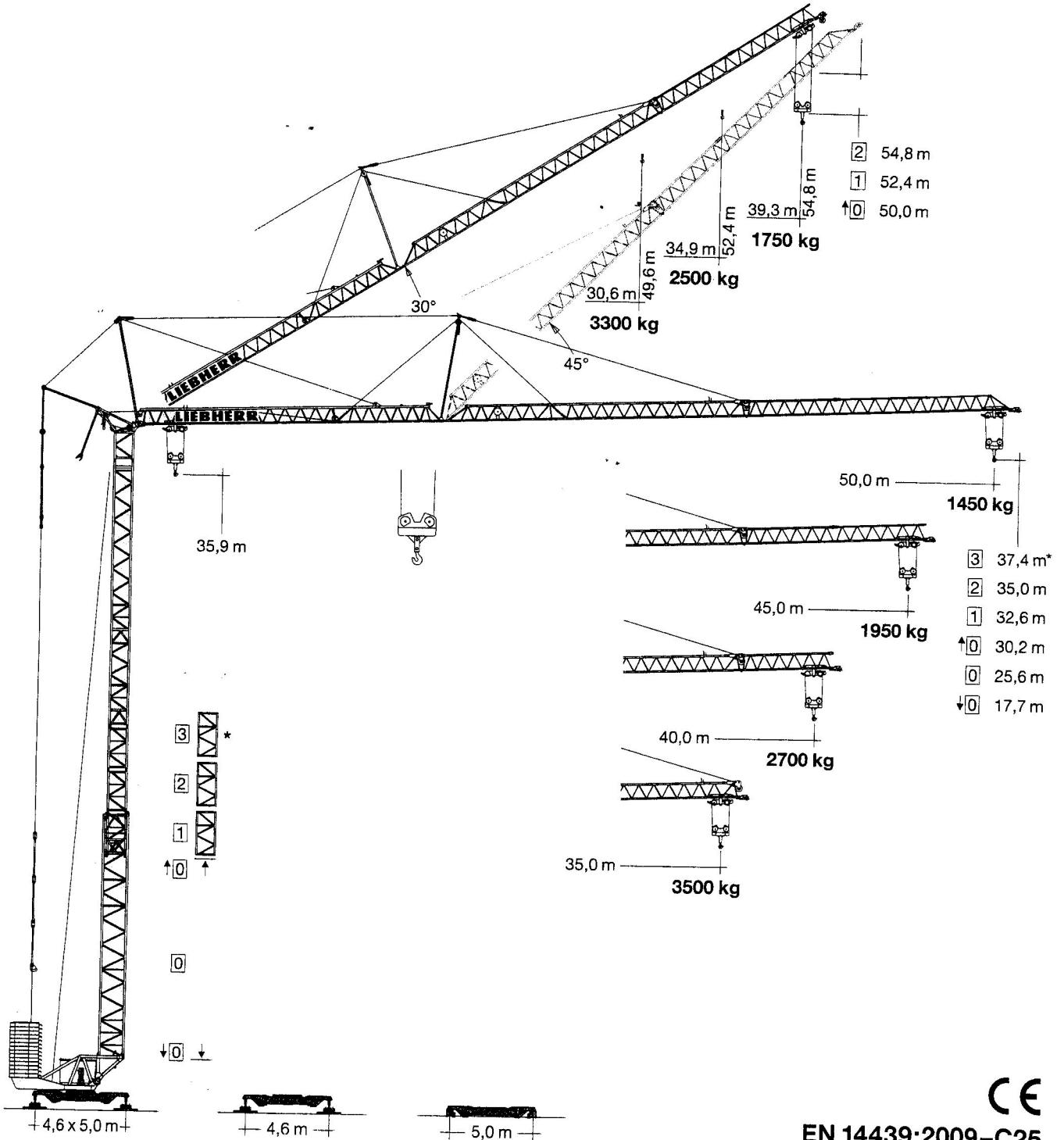

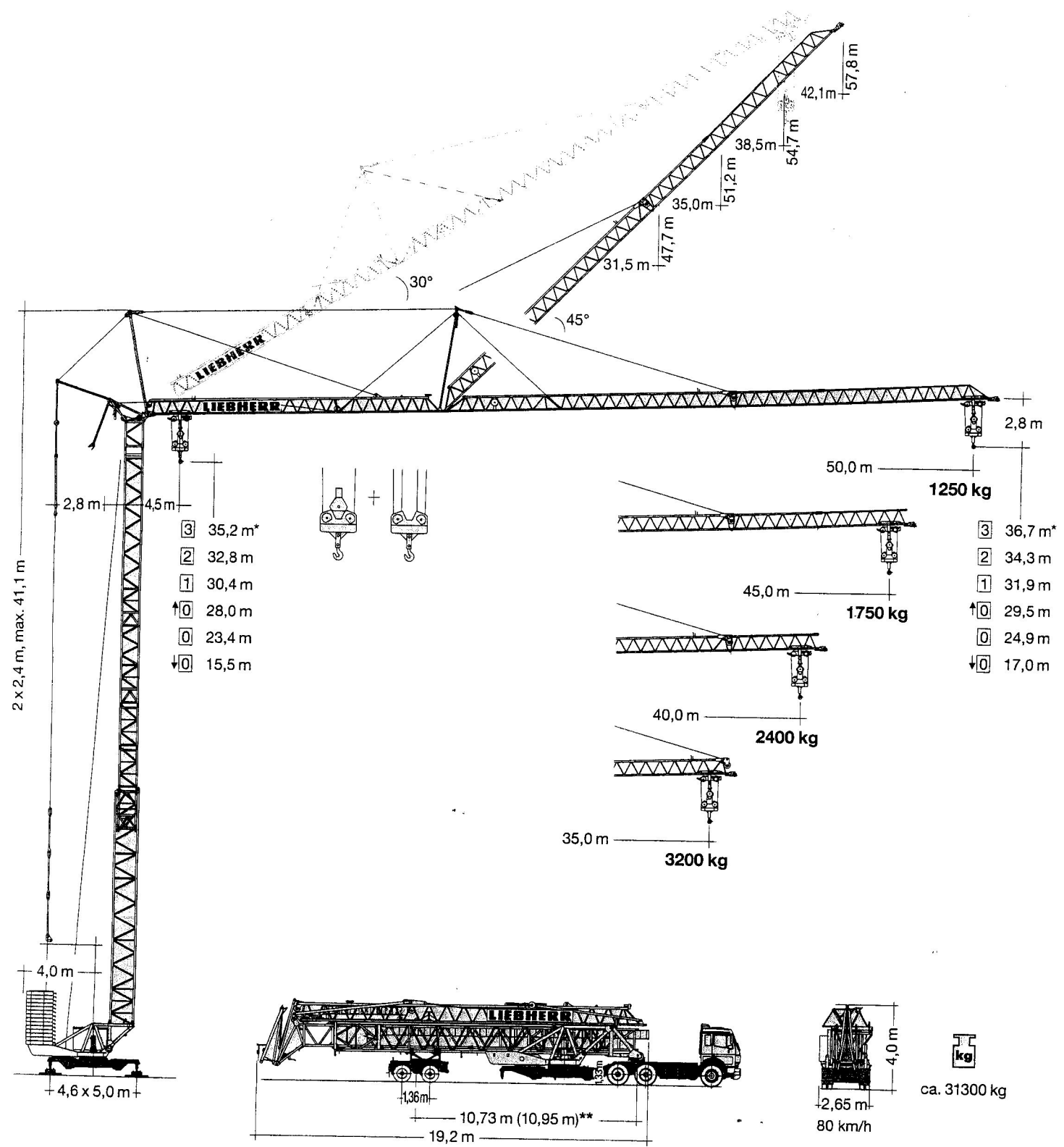

EN 14439:2009-C25

LIEBHERR







Gewicht Weight / Poids / Peso / Peso / Pesos / Macca

 <p>r = 4,0 m</p> <p>44000 kg</p>	 <p>28300 kg</p>
--	---











* siehe Betriebsanleitung. / see instruction manual. / voir manuel de service. / vedasi le istruzioni sull'uso. / según manual. / ver manual de instruções. / см. инструкцию по эксплуатации.











Ausladung und Tragfähigkeit

Radius and capacity / Portée et charge / Sbraccio e portata
Alcances y cargas / Alcance e capacidade de carga / Вылет и грузоподъемность





m	m/kg		m/kg															
			21,0	22,0	24,0	26,0	28,0	30,0	31,0	32,0	33,0	35,0	37,0	40,0	42,0	45,0	47,0	50,0
50,0	4,5 - 21,3 4000		4000	3860	3500	3190	2930	2700	2600	2500	2410	2250	2100	1910	1800	1660	1560	1450
45,0	4,5 - 24,3 4000		4000	4000	4000	3710	3400	3150	3030	2920	2820	2630	2460	2250	2120	1950		
40,0	4,5 - 27,7 4000		4000	4000	4000	4000	3950	3680	3550	3430	3320	3120	2940	2700				
35,0	4,5 - 30,4 4000		4000	4000	4000	4000	4000	4000	4000	3930	3810	3700	3500					

max. 2 Turmstücke / max. 2 tower sections / max. 2 éléments de mât / max. tre elementi torre / max. 2 tramos / max. 2 segmentos de torre / макс. 2 башенных секций











m	m/kg			m/kg															
				21,0	22,0	24,0	26,0	28,0	30,0	31,0	32,0	33,0	35,0	37,0	40,0	42,0	45,0	47,0	50,0
50,0	4,5 - 20,4 4000			3870	3660	3300	2990	2730	2510	2400	2310	2220	2060	1910	1720	1610	1460	1360	1250
45,0	4,5 - 23,3 4000			4000	4000	3860	3510	3210	2950	2830	2720	2620	2430	2270	2050	1920	1750		
40,0	4,5 - 26,5 4000			4000	4000	4000	4000	3750	3440	3310	3180	3060	2840	2650	2400				
35,0	4,5 - 29,2 4000			4000	4000	4000	4000	4000	3870	3720	3580	3440	3200						











m	m/kg			m/kg															
				21,0	22,0	24,0	26,0	28,0	30,0	31,0	32,0	33,0	35,0	37,0	40,0	42,0	45,0	47,0	50,0
50,0	4,5 - 11,2 8000			3870	3660	3300	2990	2730	2510	2400	2310	2220	2060	1910	1720	1610	1460	1360	1250
45,0	4,5 - 12,8 8000			4520	4280	3860	3510	3210	2950	2830	2720	2620	2430	2270	2050	1920	1750		
40,0	4,5 - 14,8 8000			5290	5000	4510	4100	3750	3440	3310	3180	3060	2840	2650	2400				
35,0	4,5 - 16,4 8000			5950	5630	5070	4610	4210	3870	3720	3580	3440	3200						

max. 2 Turmstücke / max. 2 tower sections / max. 2 éléments de mât / max. tre elementi torre / max. 2 tramos / max. 2 segmentos de torre / макс. 2 башенных секций

m	m/kg		Auslegerstellung 30° / Elevated jib 30° / Flèche inclinée 30° / Braccio inclinato a 30° Pluma inclinada 30° / Lança inclinada 30° / Положение стрелы под углом 30°																
			22,0	23,0	24,0	25,0	26,0	27,0	28,0	29,0	30,0	30,6	31,0	33,0	34,9	36,0	38,0	39,3	
39,3	4,5 - 18,5 4000		3340	3190	3050	2920	2800	2690	2580	2480	2390	2340	2300	2150	2010	1940	1820	1750	
34,9	4,5 - 22,1 4000		4000	3840	3680	3540	3400	3270	3150	3040	2940	2880	2840	2660	2500				
30,6	4,5 - 24,9 4000		4000	4000	4000	3980	3840	3710	3590	3470	3360	3300							

max. 2 Turmstücke / max. 2 tower sections / max. 2 éléments de mât / max. tre elementi torre / max. 2 tramos / max. 2 segmentos de torre / макс. 2 башенных секций

m	m/kg			m/kg															
				21,0	22,0	24,0	26,0	28,0	30,0	31,0	32,0	33,0	35,0	37,0	40,0	42,0	45,0	47,0	50,0
50,0	4,5 - 18,8 4000			3560	3390	3080	2820	2590	2400	2310	2220	2140	1990	1860	1690	1580	1450	1360	1250
45,0	4,5 - 21,6 4000			4000	3930	3600	3300	3050	2830	2720	2630	2540	2370	2220	2030	1910	1750		
40,0	4,5 - 25,0 4000			4000	4000	4000	3850	3560	3310	3190	3090	2980	2790	2630	2400				
35,0	4,5 - 28,5 4000			4000	4000	4000	4000	4000	3780	3650	3530	3410	3200						

m	m/kg			m/kg															
				21,0	22,0	24,0	26,0	28,0	30,0	31,0	32,0	33,0	35,0	37,0	40,0	42,0	45,0	47,0	50,0
50,0	4,5 - 9,0 8000			3560	3390	3080	2820	2590	2400	2300	2220	2140	1990	1860	1690	1580	1450	1360	1250
45,0	4,5 - 10,3 8000			4130	3930	3590	3300	3050	2830	2720	2630	2540	2370	2220	2030	1900	1750		
40,0	4,5 - 12,0 8000			4770	4560	4180	3850	3560	3300	3190	3090	2980	2790	2630	2400				
35,0	4,5 - 14,0 8000			5450	5200	4770	4390	4070	3780	3650	3530	3410	3200						

* 3 Turmstücke / 3 tower sections / 3 éléments de mât / tre elementi torre / 3 tramos / 3 segmentos de torre / 3 башенных секций

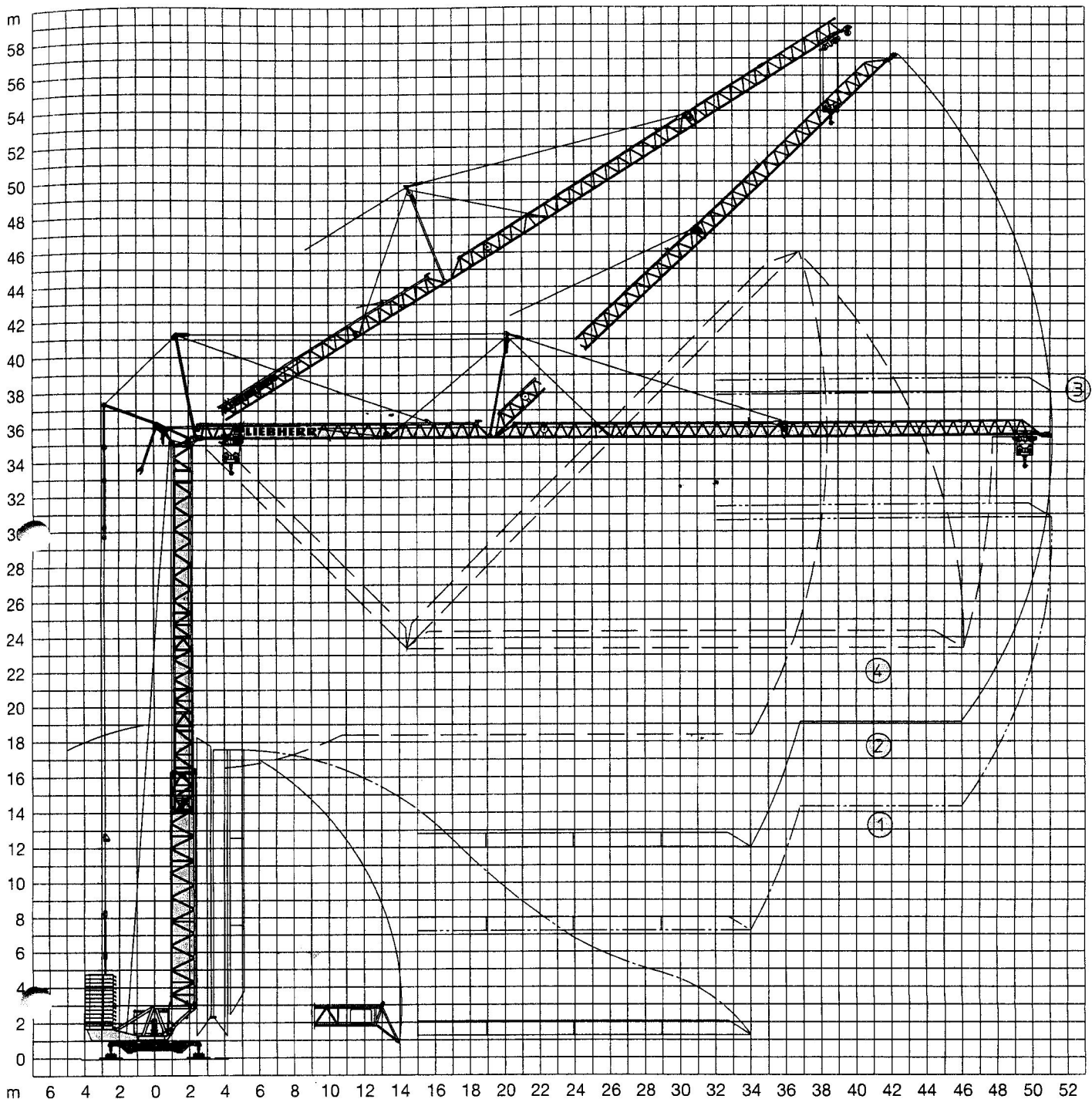

①
ohne Turmstück
 without tower section
 sans éléments de mât
 senza elementi di torre
 sin tramo de torre
 sem tramo de torre
 без башенных секций



②
2 Turmstücke
 2 tower sections
 2 éléments de mât
 2 elementi di torre
 2 tramos de torre
 2 tramos de torre
 2 башенные секции

③
3 Turmstücke, reduzierte Lastkurve
 3 tower sections, reduced load curve
 3 éléments de mât, courbe de charge réduite
 tre elementi torre, curva di carico ridotta
 3 tramos de torre, curva de carga rebajada
 3 segmentos de torre, curva de carga reduzida
 3 башенные секции, сокращенная кривая грузоподъемности

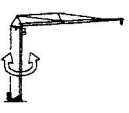
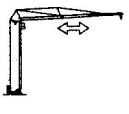
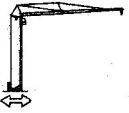
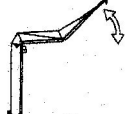
④
Hohe Aufstellkurve, 2 Turmstücke
 High erecting curve, 2 tower sections
 Courbe de montage haute, 2 éléments de mât
 Elevata curva di montaggio, due elementi torre
 Mayor curva de desarrollo de montaje, 2 tramos de torre
 Montagem elevada, 2 segmentos de torre
 высокая монтажная траектория, 2 башенные секции

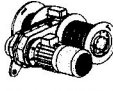
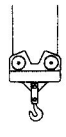
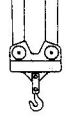









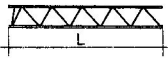

	U/min. 0 ↔ 0,8 st./min tr./min	7,5 kW FU
	0 ↔ 70,0 m/min	5,0 kW FU
	25,0 m/min	2 x 3,0 kW FU
	0 ↔ 45°, 2 min.	5,0 kW FU

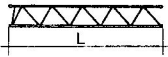
	↔ stufenlos / stepless / régl. continu regl. progressiva / sin escalones sem degraus / бесступенчатый
22,0 kW FU WIW 230 LX 020	kg m/min
	
Gang Speed Vitesse Marcia Velocidad Velocidade Передача	1 4000 0 ↔ 25,0 1500 0 ↔ 58,0
	
Gang Speed Vitesse Marcia Velocidad Velocidade Передача	1 8000 0 ↔ 12,5 3400 0 ↔ 29,0

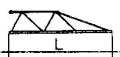
BGL		C.0.08.0112		+		C.0.08.0100
------------	--	-------------	--	---	--	-------------

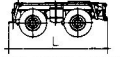
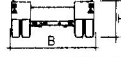
	400 V	Hz	kVA
110,0 m	4 x 16 mm ²	50	32,0

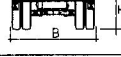
Kolli-Liste Packing List / Liste de colisage / Lista dei colli
Lista de contenido / Lista de embalagem / Упаковочный лист

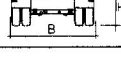
Pos. Item Rep. Voce Pos. Ref. Поз.	Anz. Qty. Qte. Qta. Cant. Cant. Кол-во		L (m)	B (m)	H (m)	kg		
1	2	Turmstück (mit Turmauflage) / Tower section (with tower support) / Élément de mât (avec support de mât) / Elemento di torre (con pedana di servizio) / Tramo de torre (con soporte de torre) / Tramo de torre (com suporte de torre) / Башенная секция (с упорами)			2,52	1,11	1,11	780
2	1	Ausleger-Verlängerung 35,0 m – 40,0 m Jib extension / Rallonge de la flèche Elemento estensione braccio / Prolongación de pluma / Extensão da lança / Удлинение стрелы			5,24	1,02	0,99	350
3	1	Ausleger-Verlängerung 40,0 m – 45,0 m Jib extension / Rallonge de la flèche Elemento estensione braccio / Prolongación de pluma / Extensão da lança / Удлинение стрелы			5,16	1,02	0,92	220
4	1	Ausleger-Verlängerung 45,0 m – 50,0 m Jib extension / Rallonge de la flèche Elemento estensione braccio / Prolongación de pluma / Extensão da lança / Удлинение стрелы			4,73	1,02	0,89	170
5	1	Transportachse Tra 203 / Road transport axle Essieux de transport / Assali par trasporto / Eje de transporte / Eixo de transporte / Транспортная ось			3,00	2,50	1,20	2500
6	1	Transportachse Tra 204 / Road transport axle Essieux de transport / Assali par trasporto / Eje de transporte / Eixo de transporte / Транспортная ось			3,10	2,50	1,10	1900
7	1	Transportachse Tra 205 / Road transport axle Essieux de transport / Assali par trasporto / Eje de transporte / Eixo de transporte / Транспортная ось			3,00	2,50	1,20	3000
8	1	Kiste mit Kleinteilen, Seilen / Crate with small parts, ropes Caisse contenant des accessoires, câbles / Cassa con minuteria, funi / Caja con piezas pequeñas, cables / Caixa com peças pequenas, cabos / Ящик с мелкими деталями, с канатами			1,00	0,80	1,00	450